

**SYSTEM  
PLAST™**

# Unit Material Handling Conveyor Solutions

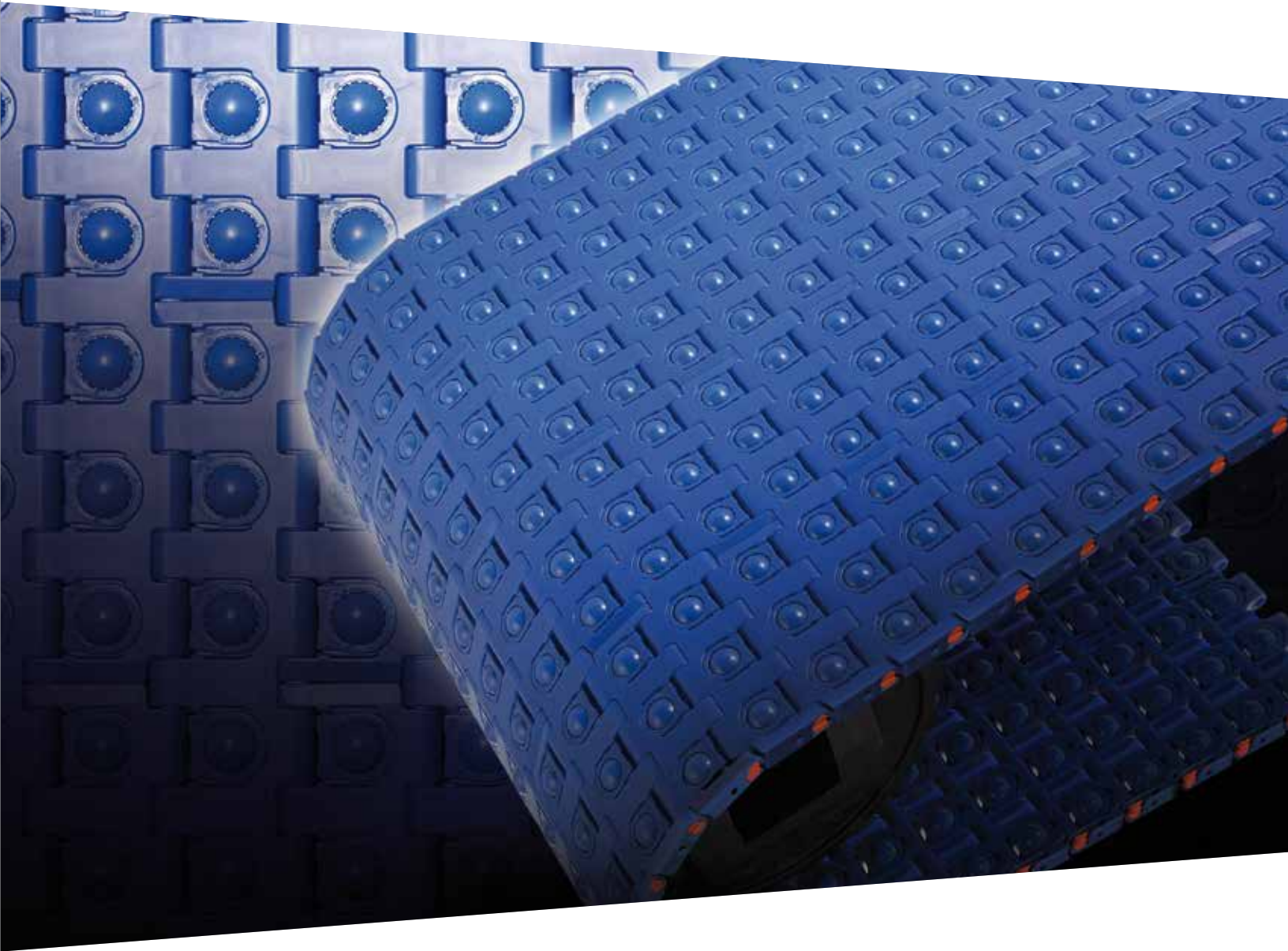

A Regal Brand

**REGAL**

# 2253 RT

# ROLLER TOP IMPERIAL SIZE (PITCH 1" - 25.4 mm)

**Backflex radius:**

40 mm - 1.575 inch.

**Max load capacity:**

9.000 N/m - 617 lbs/ft

**Max load per ball:** 0.5 kg

**Weight:** 10.5 kg/m<sup>2</sup> - 2.15 lb/ft<sup>2</sup>

**Standard length:**

Up to 9 inch width: 1.016 mm - 40 inch

Above 9 inch width: 508 mm - 20 inch

**Standard pin material:** PBT (white)

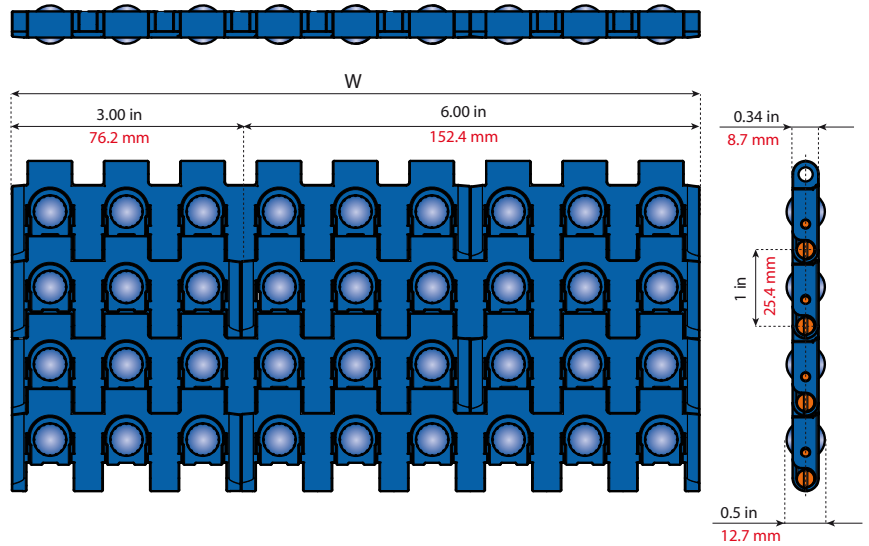

Standard Material

**LFB**

Low Friction Acetal  
(standard material  
color Blue)

Width W		Item Description	Item #
inch	mm		
3.00	76	LFB2253RT-K300	261400LFB
6.00	152	LFB2253RT-K600	261401LFB
9.00	229	LFB2253RT-K900	261402LFB
12.00	305	LFB2253RT-K1200	261403LFB
15.00	381	LFB2253RT-K1500	261404LFB
18.00	457	LFB2253RT-K1800	261405LFB
21.00	533	LFB2253RT-K2100	261406LFB
24.00	610	LFB2253RT-K2400	261407LFB
27.00	686	LFB2253RT-K2700	261408LFB
30.00	762	LFB2253RT-K3000	261409LFB
33.00	838	LFB2253RT-K3300	261410LFB
36.00	914	LFB2253RT-K3600	261411LFB
39.00	991	LFB2253RT-K3900	261412LFB
42.00	1067	LFB2253RT-K4200	261413LFB
45.00	1143	LFB2253RT-K4500	261414LFB

Width W		Item Description	Item #
inch	mm		
48.00	1219	LFB2253RT-K4800	261415LFB
51.00	1295	LFB2253RT-K5100	261416LFB
54.00	1372	LFB2253RT-K5400	261417LFB
57.00	1448	LFB2253RT-K5700	261418LFB
60.00	1524	LFB2253RT-K6000	261419LFB
63.00	1600	LFB2253RT-K6300	261420LFB
66.00	1676	LFB2253RT-K6600	261421LFB
69.00	1753	LFB2253RT-K6900	261422LFB
72.00	1829	LFB2253RT-K7200	261423LFB
75.00	1905	LFB2253RT-K7500	261424LFB
78.00	1981	LFB2253RT-K7800	261425LFB
81.00	2057	LFB2253RT-K8100	261426LFB
84.00	2134	LFB2253RT-K8400	261427LFB
87.00	2210	LFB2253RT-K8700	261428LFB
90.00	2286	LFB2253RT-K9000	261429LFB

# 2253 RT

# SPROCKETS and IDLER WHEELS

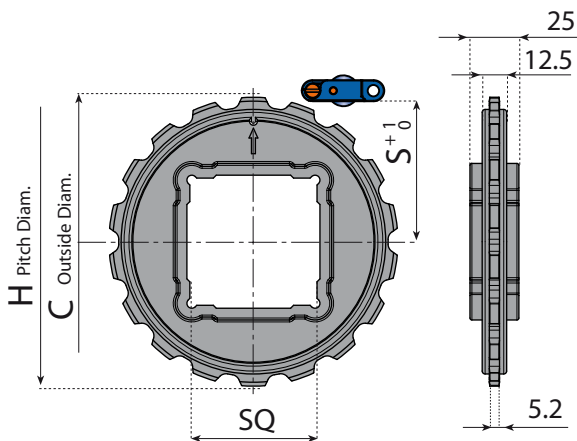

Z	C mm	H mm	S mm
18	147.65	146.3	68

ONE PIECE SPROCKETS - Floating	
Part number	Part number
2253RT-18S40M-DM	2253RT-18S1.5-DM

Material: polyamide.

## 2253 Roller Top Belt

The 2253 RT is a new development in our 1" pitch, 8,7 mm thick modular belts. The design of this belt allows products to move in any direction you want, giving you extensive flexibility to orient your products. Speeding up, opening gaps or slowing down to close gaps, are some of the possibilities with our Roller Top Belt. Product positioning can be accomplished smoothly and effortlessly.



### Materials

System Plast™ uses only first class materials for this modular belt. The modules are made of LFB, blue acetal. This offers a high belt strength in combination with low friction. The balls are made of very tough and wear resistant Polyamide.



### Quality

System Plast sets the global standard in low-friction flat-top conveyor, with resins scientifically engineered for optimum material handling performance, and ISO-certified manufacturing operations. It's all backed by engineering support and a full range of accessory products to complete a system that meets your uptime and throughput objectives.

## Freedom of movement!

2253 RT is designed for products with flat bottom surfaces, such as boxes, trays or stacks of cardboard. In the packaging area of a bottle line, 6-pack containers can be precisely positioned before they are further boxed or palletized. Distribution centers may select items for pallet loading by shifting the package sideways without the use of mechanical pushers. In the corrugated paper industry, the 2253 RT belt can be used to reduce package damage by transferring your stacks of cardboard without the use of pushers or external guides. The 2253 RT provides a touchless conveying solution.

## Application examples

### Product positioning

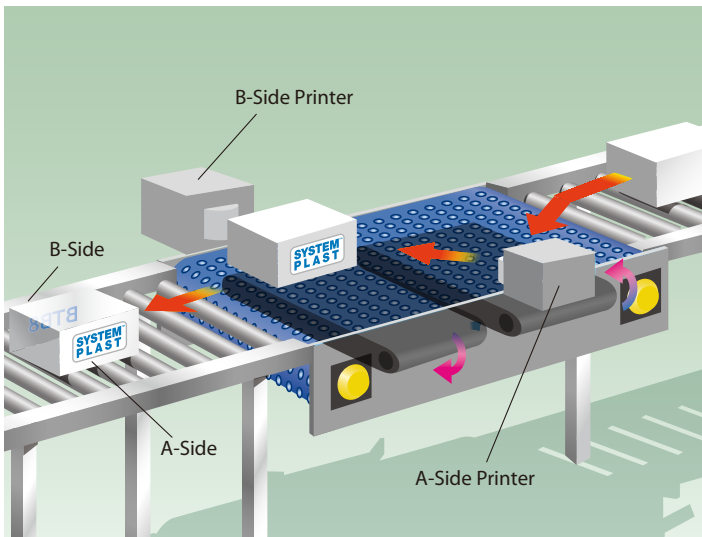

### Product orientation

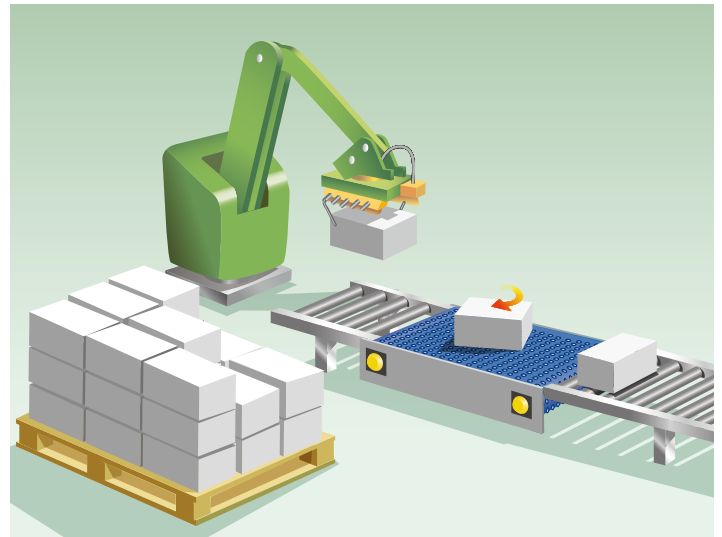

### Reject stations

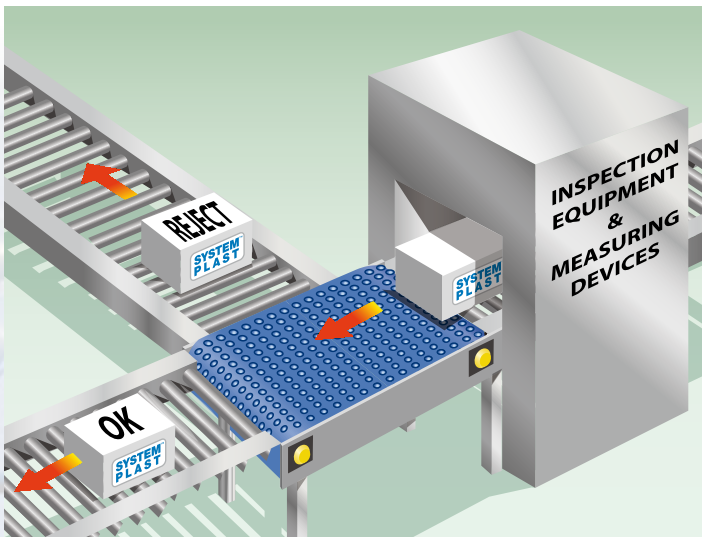

### Automatic storage systems

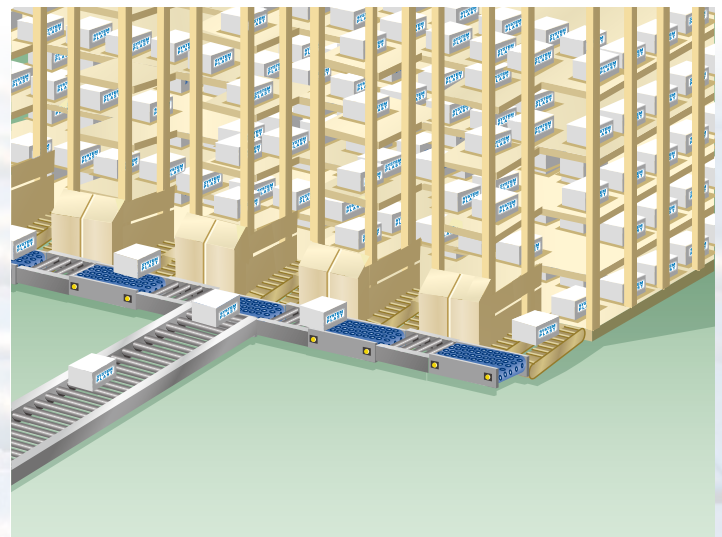

Please contact our Technical Service team at 800-626-2093 for more information.

## Double speed

When the belt is moving and the rollers are in contact with a fixed support area, the rollers will start rotating. This will result in movement of the product with a speed that is twice the speed of the belt. This function is very useful when products must be separated from each other. This function enables the belt to run at lower speed, which improves belt life and reduces energy consumption.

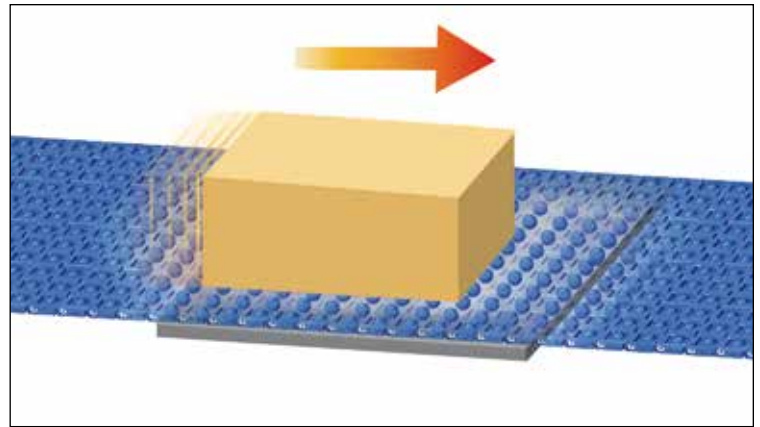

## Rotation with product moving

When two parallel running belts are positioned underneath the Roller Top belts, and running in different directions, containers in the middle of the belt will rotate. This condition is ideal for applications where product orientation is important, for example, the infeed to a palletizer. In this case, containers can be moving forward while rotating.

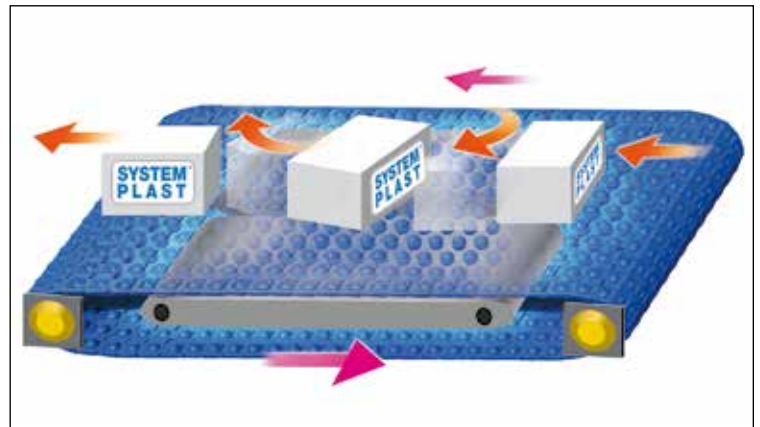

## Rotation with product stopped

When using a rotating disc underneath the Roller Top belt, you can have optimum control of the rotation of the product.

The Roller Top belt must be stopped during rotation.



## Lateral movement

With a secondary activated belt positioned 90 degrees to the travel direction of the Roller Top belt, the system can transfer your package without external guides. This scenario is ideal for reject conveyors or any application requiring rapid 90 degree transfer of the conveyed item. Product positioning can also be achieved by this configuration.

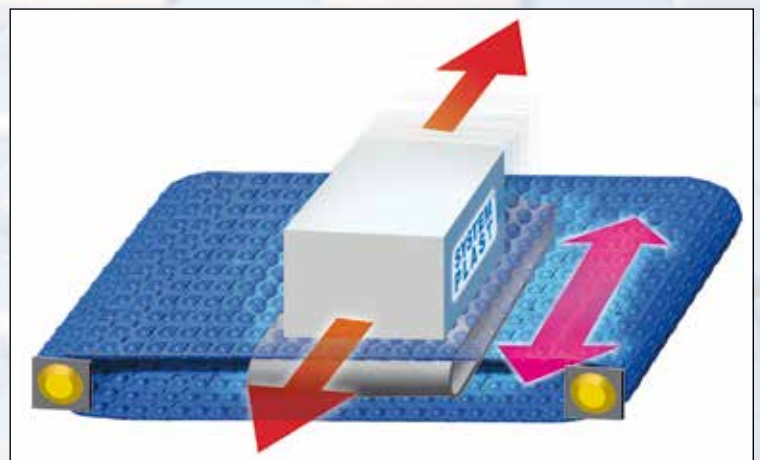

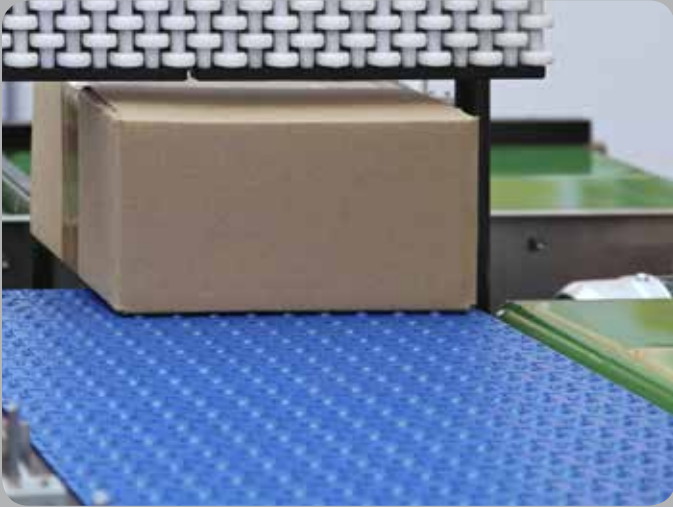

 [Twitter.com/FoodBevSustain](https://twitter.com/FoodBevSustain)

## SYSTEM PLAST™

Regal Power Transmission Solutions  
7120 New Buffington Road  
Florence, KY 41042

Customer Service: 800-626-2120

Fax: 800-262-3292

Technical Service: 800-626-2093

[www.RegalPTS.com](http://www.RegalPTS.com)

### APPLICATION CONSIDERATIONS

The proper selection and application of power transmission products and components, including the related area of product safety, is the responsibility of the customer. Operating and performance requirements and potential associated issues will vary appreciably depending upon the use and application of such products and components. The scope of the technical and application information included in this publication is necessarily limited. Unusual operating environments and conditions, lubrication requirements, loading supports, and other factors can materially affect the application and operating results of the products and components and the customer should carefully review its requirements. Any technical advice or review furnished by Regal-Beloit America, Inc. and its affiliates with respect to the use of products and components is given in good faith and without charge, and Regal assumes no obligation or liability for the advice given, or results obtained, all such advice and review being given and accepted at customer's risk.

For a copy of our Standard Terms and Conditions of Sale, Disclaimers of Warranty, Limitation of Liability and Remedy, please contact Customer Service at 1-800-626-2120. These terms and conditions of sale, disclaimers and limitations of liability apply to any person who may buy, acquire or use a Regal-Beloit America Inc. product referred to herein, including any person who buys from a licensed distributor of these branded products.

Regal and System Plast are trademarks of Regal-Beloit Corporation or one of its affiliated companies.  
©2015 Regal-Beloit Corporation. All Rights Reserved. MCB15005E • Form# 22481E • Printed in USA

A Regal Brand

**REGAL**

[www.regalbeloit.com](http://www.regalbeloit.com)